

## DESIGN AND CONSTRUCTION OF VERY LOW FREQUENCY ANTENNA

M. Waheed-uz-Zaman<sup>1\*</sup> and M.A.K. Yousufzai<sup>1,2</sup>

<sup>1</sup>Institute of Space and Planetary Astrophysics, University of Karachi, Karachi, Pakistan

<sup>2</sup>Department of Applied Physics, University of Karachi, Karachi, Pakistan

### Abstract

Communication with submerged submarines requires specific techniques and devices which gives totally different criteria as compared to the air. In the ocean salts water provide a hindrance for electromagnetic radiation such as normal radio communication because sea water acts as thick conductors. It is the normal practice in submarine is to surface and raise an antenna above the water surface to use standard technology. In case of nuclear-powered submarines it is very difficult to come on surface for communication. A thorough research it was analyzed by the scientists that VLF radio waves (3-30 KHz) can penetrate sea water down to a depth of roughly 20 meters. It's really a backup of existing, higher-frequency, radio-based communication systems. Moreover the rate of information and speed of transmission of other systems, it "gets through" while the others cannot. Previously it was a one-way, non-voice system, but it provides sufficient information to the submarine's commander to surface to receive more information via other means but in this paper a view is given to the readers the both way communication under water with submarines. This is an experimental effort to enquire the live data and with the passage of time and effort it can be used for both way communications between two submarines.

**Keywords:** VLF antenna, propagation in sea water, radio waves communication, nuclear submarine.

### INTRODUCTION

Submarines are totally blind when they are submerged and in some cases it is necessary for the ships to communicate with submerged submarines. In the submarine the paramount importance is the safety of the submarine and its crew. In the normal practice and especially during exercise the ships can advise the submarine when it is safe to surface. The ship can be so informed if any emergency onboard submarine. Exercise can be started and stopped, or one in progress can be modified. It is very useful for the submarine to be signaled the attack accuracy by submarine to the attacking ship. There are either one or two way voices or tone/sound signal generation, utilizing sonar or sonobuoy type equipment. In this condition the sea water is the medium for radio wave propagation and the range and quality of transmission varies with water conditions, local noise level, and reverberation effects. Submarine can achieve the range more than out to 12,000 meters if the submarines are operating in a sound channel, the communication range may be many kilometers greater than that achieved by ships. Severe reverberation effects and local noise, caused by ship's movement through the water, machinery, screws, etc., can reduce the range to less than half the normal range. The physical characteristics of the sea of underwater sound transmission, the amount of data/information that can be communicated through sonic means is severely limited. After realizing sonic limitation it is conclude that the

primary and most reliable means of communications between submarines and other forces/command structure is with various radio systems. We can say that the only and major disadvantage is the submarine to come upto the periscope depth to use these radio communication systems. The only reliable and safety communication is the ELF communications systems which make use of a principle in physics where the attenuation of radio waves (electromagnetic waves) from sea water increases with the frequency of the signal. This means that the lower the frequency a radio transmission, the deeper into the ocean a useable signal will travel with feasible sea condition but it is very difficult to construct such type of small ELF antenna which used in both ways. Radio waves in the very low frequency (VLF) band at frequencies of about 20,000 Hertz (Hz) penetrate sea water to depths less than the ELF waves while maintaining stealth.

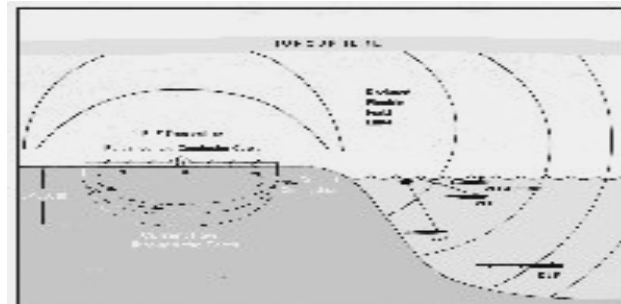

Fig. 1. The above picture shows the scheme of transmission in VLF band: transmitter station, propagation signal and receiving techniques in submarine in immersion.

\*Corresponding author: E-mail: mwaheed\_06@yahoo.com

**THEORY**

Antenna is a device which is used to transmit or receive the continuous wave energy radiated oscillates at radio frequencies. The extreme lowest frequency the size of the antenna in length from thousands of meters, whereas the extreme high frequency range the size of the antenna is in fractions of a millimeter. Short radio waves and long infrared waves overlap into a twilight zone that may be regarded as belonging to both.

The wavelength  $\lambda$  of a wave is related to the frequency  $f$  and velocity  $v$  of the wave by

$$\lambda = \frac{v}{f} \tag{1}$$

Thus in the above-mentioned parameters, the wavelength depends on the velocity  $v$  which depends on the medium. In the free space frequency is a more fundamental quality since it is independent of the medium.

$$v = c = 3 \times 10^8 \text{ m/s} \tag{2}$$

$$\lambda = \frac{c}{f} = 3 \times 10^8 / 3000 \times 10^6 \tag{3}$$

To design the Very Low Frequency (VLF) transmitting antenna design is a specialized field of engineering and it is only possible to have the combined skill of radio, civil and mechanical engineers. The antenna system especially used for this antenna (15-30 kHz) is enormous structures. Previously fixed site very low frequency transmit antenna systems are used by USA and Russia as the primary means of communication to submarine at sea. In the present scenario there has not been a system to measure important antenna parameters on this low frequency transmit antennas in near real time while the antenna is being driven by frequency shift modulation. The important features are considered during construction of an antenna are: voltage and current signals to calculate the antenna system resistance, capacitance, and inductance, voltage, current and power.

**VLF Band**

VLF (Very Low Frequency) Band takes place from 3 kHz to 30 kHz in the frequency spectrum

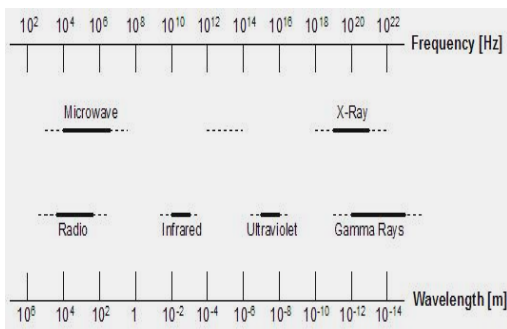

Fig. 2. Frequency bands

**E and H fields**

The E and H fields are:

$$I(t) = \sqrt{2I} \cos(wt) \tag{4}$$

$$E_z(t) = -E_\theta(t) \text{ when } \theta = 90^\circ$$

$$E_z = \frac{I h_e w}{2\pi \epsilon_0 v_0^2 d} \tag{5}$$

rms vertical electric field

$$H_\phi = \frac{I h_e w}{2\pi v_0 d} \tag{6}$$

**Radiated Power**

$$P_r = \frac{4\pi d^2}{G} \frac{E_z^2}{\eta_0} \approx \frac{E_z^2 d^2}{90} \tag{7}$$

The equivalent antenna circuit is given below

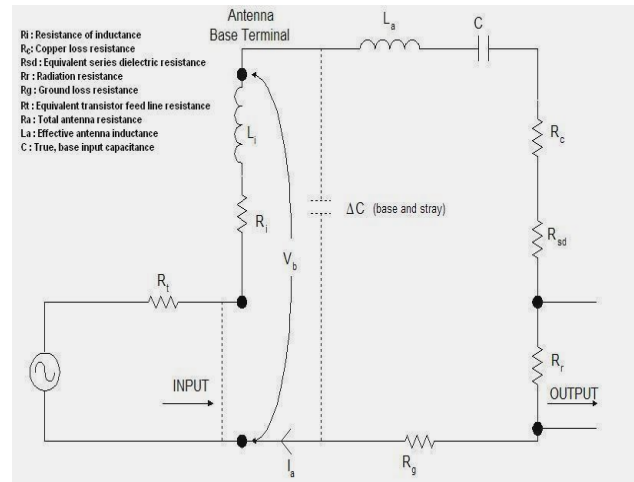

Fig. 3. Equivalent antenna circuit

The radiation efficiency of the antenna is given as:

$$\eta_a = \frac{R_r}{R_a} \tag{8}$$

Where

$$R_a = R_r + R_l$$

$$R_l = R_{sd} + R_c + R_g$$

and Antenna loss resistance

$$\eta_{as} = \frac{R_r}{(R_a + R_l)} \quad (\text{as: antenna system}) \quad (9)$$

$$\eta_{ts} = \frac{R_r}{(R_a + R_l + R_t)} \quad (\text{ts: transmitting system}) \quad (10)$$

**CONSTRUCTION**

In the design of VLF antenna we have used especial method of design methodology. We used copper wires which are rewound just like a transformer core in either direction to cover the al around communication. The gap between the two windings is filled with mica and wood by considering the good magnetic properties especially for mica. In this construction we can't ignore the basic parameters without which it is very difficult to fulfill a good and efficient antenna. The low power modulated and amplifier circuit is design to transmit the signal for short distance. This is an experimental effort to enquire the live data and with the passage of time and effort it can be used for both way communications between two submarines. The construction of the antenna can easily be evaluated by observing the figures below:

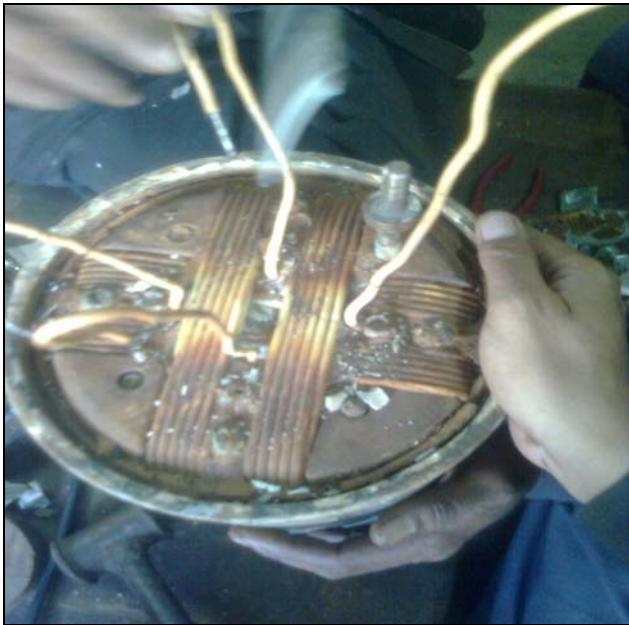

Fig. 4. The over view of the antenna showing the formation of the coils



Fig. 5. Side view of the antenna showing coils the coils formation.



Fig. 6. Side view of the antenna showing the ferrite material.



Fig. 7. Antenna after insulated

**TESTING OF VLF ANTENNA**

To test the constructed antenna in the laboratory following setups are required. The main things are the power amplifier and matching unit.

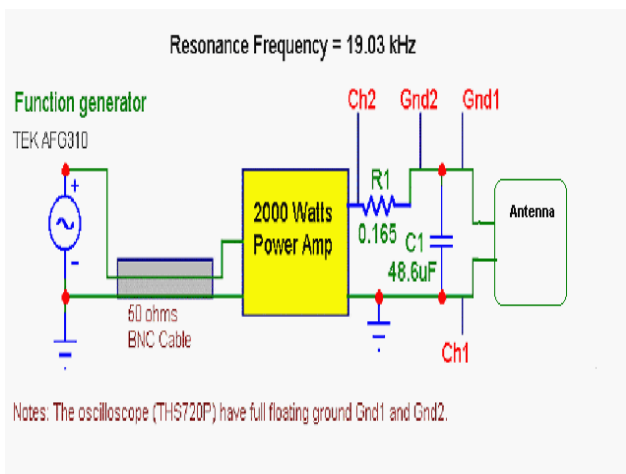

Fig. 8. Tuning/Testing setup

The all testing and observed signals were thoroughly monitored through oscilloscope to check the performance of the antenna. It is really a difficult task but not impossible to design a VLF antenna which can be used underwater for submarine communications. Following figures clearly define the wave pattern of a signal.



Fig. 9. Modulated wave pattern of the transmitting waves.

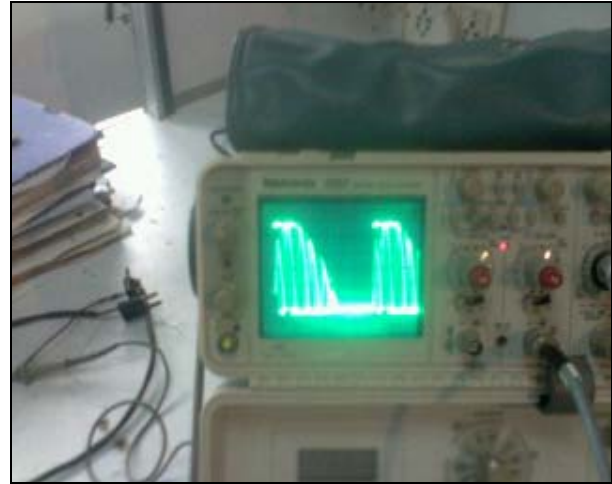

Fig. 10. Half wave pattern of the transmitting waves.

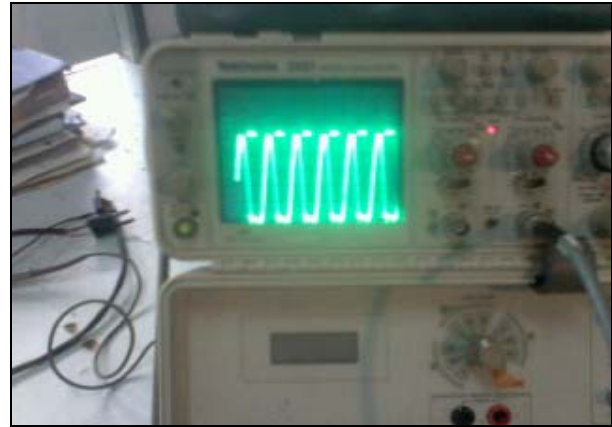

Fig. 11. Wave pattern of a transmitting wave.

**APPLICATIONS**

Some applications of VLF antenna are given below:

1. EM Wave requires at VLF because of skin effect.
2. In VLF electric and magnetic dipoles can be used because the propagation in sea water is almost vertical.
3. In VLF output power must be high enough to reach receiver due to attenuation.

$$\delta = \sqrt{\frac{2}{\omega \mu_0 \sigma}}$$

4. We can used this type of antenna for mine disaster.
5. It can provide wireless communication between earth's surface and miner.

6. There is less attenuation than other VLF Band is used.
7. We design VLF Loop antenna for this purpose.

## CONCLUSION

In this research paper we conclude that only efficient EM power transfer can be possible due to good coupling between the VLF antenna and its surrounding medium. We conduct some measurements and tests for finding the real specifications. These test and measurements help me to calculate the proper size of the new VLF antenna which will be able to resonant at the required frequency and it is confirmed that a high frequency antenna encapsulated by a medium with permeability and conductivity is able to radiate power in the ELF/VLF range. In this experiment research the main purpose to calculate and check the small radiation efficiencies of a VLF antenna.

## REFERENCES

- Arthur DW, 1967. VLF Radio Engineering, Pergamon Press.
- Bean, BR. and Dutton, EJ. 1992. Radio Meteorology. National Bureau of Standards Mono graph
- Burke, GJ., and Miller, EK. 1983. Modeling Antennas Near to and Penetrating a Lossy Surface. Lawrence, Livermore Lab. Rept. 89838.
- Terman, FE. 1943. Radio Engineers' Hand book, 776-800, McGraw-Hill Book Company.
- Fleeming, RH. Johnson, MW. and Sverdrup, H U. 1982. The Oceans. Prentice-Hall, Inc. NJ. USA. 1511 – 1523.
- Elpidio L. 2006. Practical Antenna Design 140-150 MHz VHF Transceivers Third Edition. Technology & Engineering.
- Gordon and Breach, 1989. Antenna Driven by Modulation of Ionospheric Currents, Science Publishers, Inc. printed in Great Britain.
- Harold AW, 1988. Fundamental Relations in the Design of a VLF Transmitting Antenna, Antennas and Propagation, Volume: 6(1)1958 120 - 122
- Harold A.W, 1988. "Fundamental Limitations of a Small VLF Antenna For Submarines, Antennas and Propagation, Volume: 6(1) Jan 1958:123 – 125
- Kummer, WH. and Gillespie, ES. 1978. Antenna Measurements. IEEE, 66, 483-507.
- Kraus, JD. 1950. Antennas, McGraw-Hill Book Company.
- Menard, HW. 1990. Ocean Science. WH. Freeman & Company, San Francisco. 112-115.
- Naudin and Steve. 2000. Burns Engineering the System-G device.
- Gailey, PC and Tell, RA. 1998. "An Engineering Assessment of the Potential Impact of Federal Radiation Protection Guidance on the AM, FM, and TV Broadcast Services." U.S. Environmental. Protection Agency, Non-ionizing Radiation Branch, Las Vegas, Nevada.
- Ronald WP. 1996. Electromagnetic Fields in Human Body Due To VLF Transmitter, Antennas and Propagation Society International Digest (3) 21-26, 1802 - 1805 .

Received: 31-01-2011

Accepted: 10-05-2011